

# CHICAGO

Electric<sup>®</sup> Power Tools

## ELECTRIC LONG SHAFT DIE GRINDER

Model 44141

### ASSEMBLY and OPERATING INSTRUCTIONS



**1/4" Collet Accepts Most Popular Die Grinding Accessories**

Diagrams within this manual may not be drawn proportionally.  
Due to continuing improvements, actual product may differ slightly from the product described herein.

**Distributed exclusively by Harbor Freight Tools<sup>®</sup>.**

3491 Mission Oaks Blvd., Camarillo, CA 93011

Visit our website at: <http://www.harborfreight.com>



**Read this material before using this product.  
Failure to do so can result in serious injury.  
SAVE THIS MANUAL.**

Copyright<sup>®</sup> 2000 by Harbor Freight Tools<sup>®</sup>. All rights reserved. No portion of this manual or any artwork contained herein may be reproduced in any shape or form without the express written consent of Harbor Freight Tools.

**For technical questions or replacement parts, please call 1-800-444-3353.**

REV 06b

## Specifications

RPM's	25,000 (No Load)
Load Amps	4.3
Watts	500 (120V / 60 HZ)
Collet Diameter	1/4"
Power Cord	18 Gauge / 2 Prong / Polarized
Tool Length	14-1/4"
Wheel Diameter (Maximum)	1-1/2"
Weight	4.10 Lbs.
Includes 2 Arbor Wrenches and 2 Spare Brushes	



## Save This Manual

You will need the manual for the safety warnings and precautions, assembly instructions, operating and maintenance procedures, parts list and diagram. Keep your invoice with this manual. Write the invoice number on the inside of the front cover. Keep the manual and invoice in a safe and dry place for future reference.

## Safety Warnings and Precautions

**WARNING: When using tool, basic safety precautions should always be followed to reduce the risk of personal injury and damage to equipment.**

**Read all instructions before using this tool!**

1. **Keep work area clean.** Cluttered areas invite injuries.
2. **Observe work area conditions.** Do not use machines or power tools in damp or wet locations. Don't expose to rain. Keep work area well lighted. Do not use electrically powered tools in the presence of flammable gases or liquids.
3. **Keep children away.** Children must never be allowed in the work area. Do not let them handle machines, tools, or extension cords.
4. **Store idle equipment.** When not in use, tools must be stored in a dry location to inhibit rust. Always lock up tools and keep out of reach of children.
5. **Do not force tool.** It will do the job better and more safely at the rate for which it was intended. Do not use inappropriate attachments in an attempt to exceed the tool capacity.
6. **Use the right tool for the job.** Do not attempt to force a small tool or attachment to do the work of a larger industrial tool. There are certain applications for which this tool was designed. Do not modify this tool and do not use this tool for a purpose for which it was not intended.
7. **Dress properly.** Do not wear loose clothing or jewelry as they can be caught in moving parts. Protective, electrically non-conductive clothes and non-skid footwear are recommended when working. Wear restrictive hair covering to contain long hair.
8. **Use eye and ear protection.** Always wear ANSI approved impact safety goggles.

REV 06b, 07I

Wear a full face shield if you are producing metal filings or wood chips. Wear an ANSI approved dust mask or respirator when working around metal, wood, and chemical dusts and mists.

9. **Do not overreach.** Keep proper footing and balance at all times. Do not reach over or across running machines.
10. **Maintain tools with care.** Keep tools sharp and clean for better and safer performance. Follow instructions for lubricating and changing accessories. Inspect tool cords periodically and, if damaged, have them repaired by an authorized technician. The handles must be kept clean, dry, and free from oil and grease at all times.
11. **Disconnect power.** Unplug power cord when not in use.
12. **Remove adjusting keys and wrenches.** Check that keys and adjusting wrenches are removed from the tool or machine work surface before plugging it in.
13. **Avoid unintentional starting.** Be sure the switch is in the Off position when not in use and before plugging in. Do not carry any tool with your finger on the trigger, whether it is plugged in or not.
14. **Stay alert.** Watch what you are doing, use common sense. Do not operate any tool when you are tired.
15. **Check for damaged parts.** Before using any tool, any part that appears damaged should be carefully checked to determine that it will operate properly and perform its intended function. Check for alignment and binding of moving parts; any broken parts or mounting fixtures; and any other condition that may affect proper operation. Any part that is damaged should be properly repaired or replaced by a qualified technician. Do not use the tool if any switch does not turn On and Off properly.
16. **Guard against electric shock.** Prevent body contact with grounded surfaces such as pipes, radiators, ranges, and refrigerator enclosures.
17. **Replacement parts and accessories.** When servicing, use only identical replacement parts. Use of any other parts will void the warranty. Only use accessories intended for use with this tool. Approved accessories are available from Harbor Freight Tools.
18. **Do not operate tool if under the influence of alcohol or drugs.** Read warning labels on prescriptions to determine if your judgment or reflexes are impaired while taking drugs. If there is any doubt, do not operate the tool.
19. **Use proper size and type extension cord.** If an extension cord is required, it must be of the proper size and type to supply the correct current to the tool without heating up. Otherwise, the extension cord could melt and catch fire, or cause electrical damage to the tool. This tool requires use of an extension cord of **0 to 10 amps** capability (up to 50 feet), with wire size rated at **18 AWG**. Longer extension cords require larger size wire. If you are using the tool outdoors, use an extension cord rated for outdoor use. (signified by "WA" on the jacket).
20. **Maintenance.** For your safety, maintenance should be performed regularly by a qualified technician.

Note: Performance of this tool (if powered by line voltage) may vary depending on variations in local line voltage. Extension cord usage may also affect tool performance.

**Warning:** The warnings, cautions, and instructions discussed in this instruction manual cannot cover all possible conditions and situations that may occur. It must be understood by the operator that common sense and caution are factors which cannot be built into this product, but must be supplied by the operator.

WARNING: Some dust created by power sanding, sawing, grinding, drilling, and other construction activities, contains chemicals known [to the State of California] to cause cancer, birth defects or other reproductive harm. Some examples of these chemicals are:

- Lead from lead-based paints
- Crystalline silica from bricks and cement or other masonry products
- Arsenic and chromium from chemically treated lumber

Your risk from these exposures varies, depending on how often you do this type of work. To reduce your exposure to these chemicals: work in a well ventilated area, and work with approved safety equipment, such as those dust masks that are specially designed to filter out microscopic particles. (California Health & Safety Code § 25249.5, *et seq.*)

**Warning:**

There are certain applications for which this tool was designed. Harbor Freight Tools strongly recommends that this tool not be modified and/or used for any application other than which it was designed.

**All accessories must be rated for at least 25,000 RPM.** Wheels and other accessories running over rated speed can fly apart and cause injury.

For safest operation, it is recommended that only these accessories be used with this product:

Abrasive Cut-Off Discs and Wheels  
Wire Brushes  
1/4" Shaft Grinding Wheels

Flap Wheels  
Wire Wheel Brushes  
Rotary Burrs

**Always use an approved and proper guard when using the above mentioned accessories. Each accessory must have the correct arbor size and must fit properly on the shoulder bushing. Make sure accessories are tightened down securely.**

**CAUTION: NEVER INSTALL A CARBIDE TIPPED OR STEEL CIRCULAR SAW BLADE FOR USE ON THIS DIE GRINDER. NEVER INSTALL A WOOD CARVING BLADE, CARVING DISC WITH SAW CHAIN CUTTERS, OR A CUTTING CARVING DISC ON THIS DIE GRINDER.**

## Unpacking

When unpacking, check to make sure the parts listed on page 8 are included. If any parts are missing or broken, please call Harbor Freight Tools at the number on the cover of this manual as soon as possible.

## Operation

**Caution:** Unplug the Grinder and turn the **Switch Lever (#20)** to the off position. Use Type 1 grinding wheels with a 1-1-2" maximum diameter and 1/4" maximum thickness.

1. This grinder is equipped with a **Collet Chuck (#1)**. The **Collet Chuck (#1)** is sized to accept a 1/4" mandrel. To use any other sized mandrel (ie: 1/8") you must change the **Collet Chuck(#1)**. See Figure 1

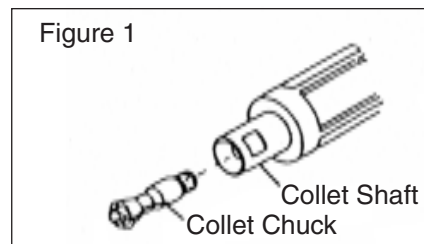

2. Rotary Files and Grinding Wheels. The maximum diameter for rotary files with a 1/4" mandrel is 3/8". The maximum diameter for grinding wheels with a 1/4" mandrel is 1-1/2". See Figure 2

**Warning:** Never use files or wheels rated below 25,000 rpm's. They can disintegrate during operation causing serious injury.

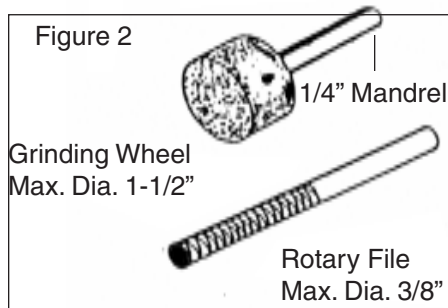

**Note:** Use grinding wheels when cutting or shaping hard materials. Use rotary files for milling soft metals, such as brass, copper, or aluminum.

3. Using the two wrenches provided with the grinder kit, attach a grinding wheel or rotary file. Hold the lower section (closest to collet shaft) of the **Collet Chuck (#1)** with one of the wrenches, while turning the **Collet Chuck (#1)** with the other wrench to loosen. See Figures 1 and 3.

4. Insert the mandrel into the **Collet Chuck (#1)** at least 5/8". Failure to do so could cause the mandrel to disengage from the **Collet Chuck (#1)** causing serious injury.

5. Using the wrenches, securely tighten the **Collet Chuck (#1)**. See Figure 3.

**Note:** Before each use, always check that the mandrel is securely fastened into the **Collet Chuck (#1)**.

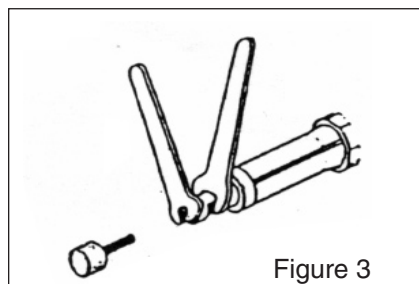

6. Make sure your hands and fingers are not touching the grinding wheel or file before starting the unit. Plug in the unit.
  7. For maximum safety and control hold the grinder with both hands away from your body. Make sure you do not cover the vents on the **Rear Cover (#36)**. Restricting air flow from the vents could cause the motor to overheat, effecting the overall life of the tool.
- Note:** Make sure your workpiece is securely clamped down.
8. Holding the unit away from your body, turn the **Switch Lever (#20)** on. See Figure 4.

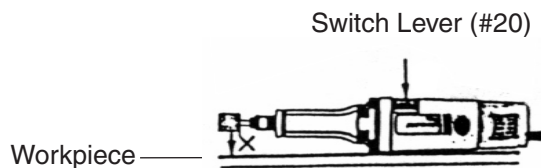

Figure 4

Gently make contact with your workpiece. Let the tool do the work. Do not force it. Excessive pressure could bend or break the mandrel causing injury. The grinder is designed to run smoothly under load. If it is not running smoothly, you are putting too much pressure on the tool.

## Maintenance

**Caution:** Before starting maintenance make sure the tool is off and unplugged.

1. This unit uses expendable **Carbon Brushes (#24)**. They need to be regularly inspected and changed if necessary. The **Carbon Brushes (#24)** will wear down to the limit line, needing replacement. Make sure the **Carbon Brushes (#24)** are always clean. They must be clean so that they easily slide into the **Carbon Brush Holder (#25)**. Use an old toothbrush to remove dirt or debris. See Figure 5 and the Assembly Diagram on page 9 of this manual.

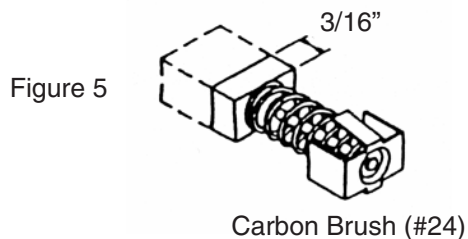

2. Changing **Carbon Brushes (#24)**.

To remove the **Carbon Brushes (#24)** use a flat screwdriver to remove the **Carbon Brush Cap (#23)**. Gently remove the **Carbon Brushes (#24)** and the spring. See Figure 5 and the Assembly Diagram on page 9 of this manual. Replace or clean the brushes and slide back into the **Carbon Brush Holder (#25)**.

3. This grinder vibrates from the high rate of rpm's utilized in operation. Frequently inspect all screws and tighten if necessary.

4. Keep all liquids away from the grinder's internal mechanism.

Any further maintenance must be performed by a authorized service technician.

## Parts List

Part No.	Description	Qty.	Part No.	Description	Qty.
1	Collet	1	23	Brush Holder Cap	2
2	Screw ST3.9x32-C-H	4	24	Carbon Brush	2
3	Front Case	1	25	Carbon Brush Holder	2
4	Washer 4	13	26	Screw ST3.9x10-C-H	1
5	Spindle	1	27	Switch	1
6	Ball Bearing 6001-2RS	1	28	Screw ST3.9x16-C-H	6
7	Retaining Ring 12	1	29	Switch Base	1
8	Ball Bearing 6200-2RS	1	31	Cover	1
9	Retaining Ring 30	1	32	Screw St3.9x13-C-H	1
10	Coupling	1	33	Cord Guard	1
11	Washer	1	34	Nut M4	2
12	Retaining Ring 22	1	35	Support	2
13	Ball Bearing 626-2RS	1	36	Rear Cover	1
14	Inner Cover	1	37	Power Cord	1
15	Armature Assembly	1	38	Description Plate	1
16	Screw	2	39	Nameplate	1
17	Ball Bearing 626-2RS	1	42	Washer	1
18	Field Assembly	1	43	Rubber Gauge Washer	1
19	Rubber Gauge Washer	1		<b>ACCESSORIES</b>	
20	Switch Lever	1	40	Wrench	1
21	Switch Pull Rod	1	41	Wrench	1
22	Motor Housing	1	24 A	Spare Carbon Brush	2

### PLEASE READ THE FOLLOWING CAREFULLY

THE MANUFACTURER AND/OR DISTRIBUTOR HAS PROVIDED THE PARTS DIAGRAM IN THIS MANUAL AS A REFERENCE TOOL ONLY. NEITHER THE MANUFACTURER NOR DISTRIBUTOR MAKES ANY REPRESENTATION OR WARRANTY OF ANY KIND TO THE BUYER THAT HE OR SHE IS QUALIFIED TO MAKE ANY REPAIRS TO THE PRODUCT OR THAT HE OR SHE IS QUALIFIED TO REPLACE ANY PARTS OF THE PRODUCT. IN FACT, THE MANUFACTURER AND/OR DISTRIBUTOR EXPRESSLY STATES THAT ALL REPAIRS AND PARTS REPLACEMENTS SHOULD BE UNDERTAKEN BY CERTIFIED AND LICENSED TECHNICIANS AND NOT BY THE BUYER. THE BUYER ASSUMES ALL RISK AND LIABILITY ARISING OUT OF HIS OR HER REPAIRS TO THE ORIGINAL PRODUCT OR REPLACEMENT PARTS THERETO, OR ARISING OUT OF HIS OR HER INSTALLATION OF REPLACEMENT PARTS THERETO.

**NOTE:** Some parts are listed and shown for illustration purposes only and are not available individually as replacement parts.



# Assembly Diagram

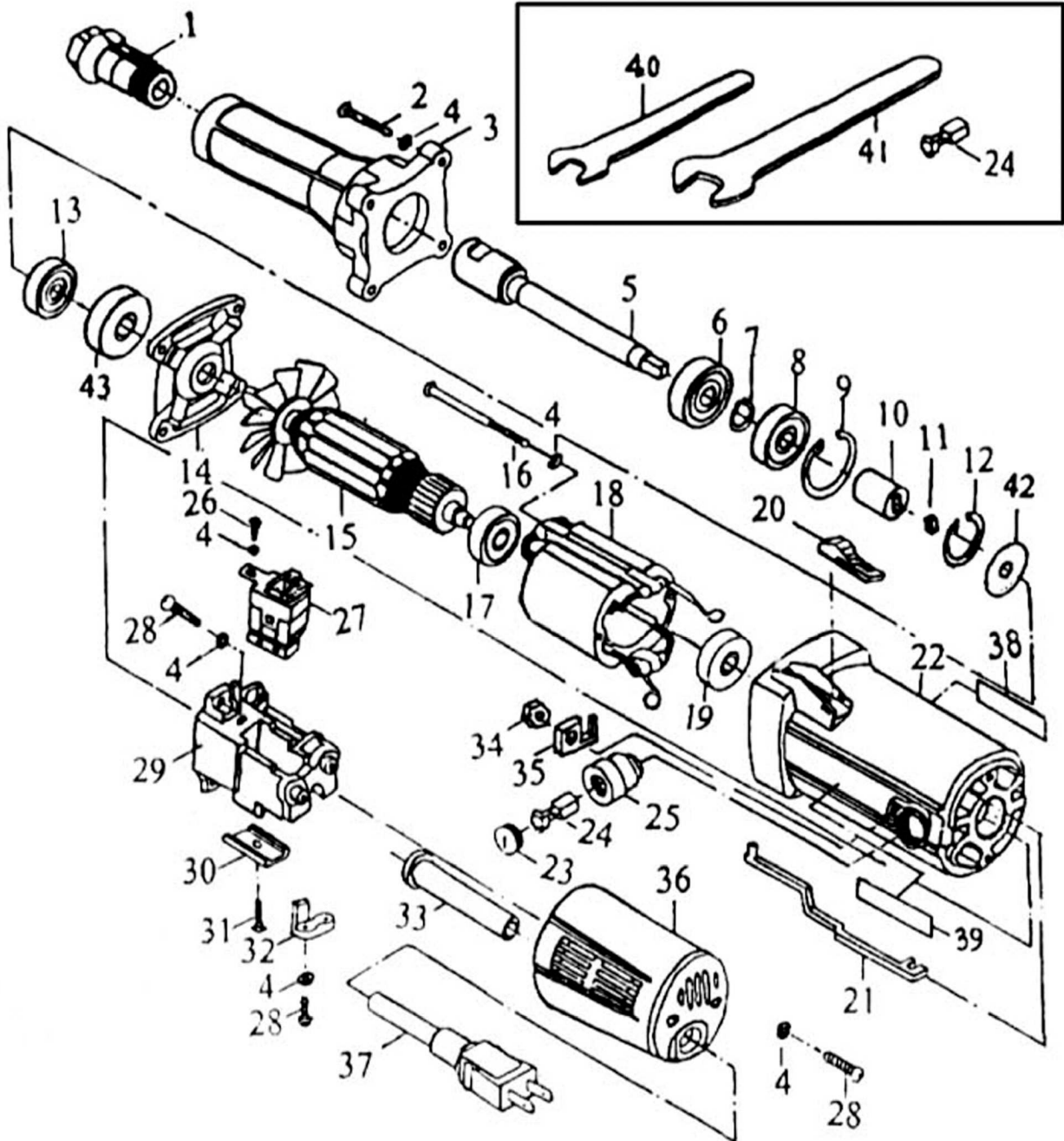

---

## LIMITED 90 DAY WARRANTY

---

Harbor Freight Tools Co. makes every effort to assure that its products meet high quality and durability standards, and warrants to the original purchaser that this product is free from defects in materials and workmanship for the period of 90 days from the date of purchase. This warranty does not apply to damage due directly or indirectly, to misuse, abuse, negligence or accidents, repairs or alterations outside our facilities, criminal activity, improper installation, normal wear and tear, or to lack of maintenance. We shall in no event be liable for death, injuries to persons or property, or for incidental, contingent, special or consequential damages arising from the use of our product. Some states do not allow the exclusion or limitation of incidental or consequential damages, so the above limitation of exclusion may not apply to you. THIS WARRANTY IS EXPRESSLY IN LIEU OF ALL OTHER WARRANTIES, EXPRESS OR IMPLIED, INCLUDING THE WARRANTIES OF MERCHANTABILITY AND FITNESS.

To take advantage of this warranty, the product or part must be returned to us with transportation charges prepaid. Proof of purchase date and an explanation of the complaint must accompany the merchandise. If our inspection verifies the defect, we will either repair or replace the product at our election or we may elect to refund the purchase price if we cannot readily and quickly provide you with a replacement. We will return repaired products at our expense, but if we determine there is no defect, or that the defect resulted from causes not within the scope of our warranty, then you must bear the cost of returning the product.

This warranty gives you specific legal rights and you may also have other rights which vary from state to state.

3491 Mission Oaks Blvd. • PO Box 6009 • Camarillo, CA 93011 • (800) 444-3353